

SY215C

SANY

Quality Changes the World

PRECISE POWER

CONSISTENTLY STRONG.
REMARKABLY VERSATILE.

CONSTRUCTION MACHINERY



CRAWLER EXCAVATOR **SY215C**

Engine
CUMMINS QSB6.7
Rated power
129 kW / 2200 rpm
Bucket capacity
1.2 m³
Operating weight
24000 kg

SANY

For challenging tasks, you need a first-class partner

Quality comes from experience. And from new ideas. This is why we combine these two crucial factors at SANY. This is because we are one of the world's leading producers, having sold more than 320 000 excavators in 10 years. This means that you can always rely on sophisticated products that have been tried and tested in practice. An impressive 5–7% of our annual turnover is dedicated to research and development.

320 000
EXCAVATORS SOLD IN
10 YEARS

5–7%
TURNOVER FOR RESEARCH
AND DEVELOPMENT

Quality Changes the World

* Applicable in certain markets, please check with your local dealer.



SY215C HARD FACTS

Max. bucket digging force
143 kN (ISO)

Max. arm digging force
115 kN (ISO)

Swingspeed
11 rpm

Max. travel speed
5.4 km/h

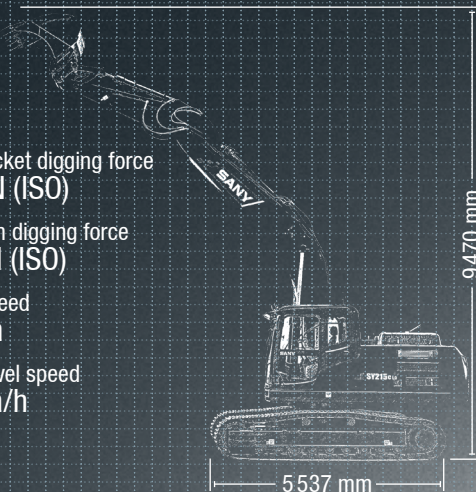



THE SPECIALIST WHEN IT COMES TO VERSATILITY

With the SANY SY215C crawler excavator, you get more done. No matter where used – it applies its power with precision. This is because every detail is specifically designed for the tough conditions on construction sites. This excavator is a real all-rounder and a specialist in every discipline, from quick loading to precise digging and powerful demolition work.

What particularly sets it apart is its ability to control its tremendous power with great precision – for maximum productivity and therefore a fast return on investment.

TOP PROPERTIES

ECONOMY

IT IS AS LOW IN CONSUMPTION AS IT IS POWERFUL IN PERFORMANCE

The highly efficient engine with common rail technology guarantees excellent performance. Four different operating modes for the various operating conditions precisely adjust the engine and hydraulic power to the requirements. This improves the excavator's response behaviour and ensures lower fuel consumption and reduced emissions.

QUALITY

Durable and robust – the SY215C can be used whenever the going gets tough. This means that it must be able to withstand a great deal. No problem for the SY215C, as with its reinforced, extremely robust undercarriage and particularly clean, robot-welded seams, it is exactly the right excavator for hard day-to-day work on construction sites.

USER EXPERIENCE

Comfortable workstation – the cabin of the SY215C leaves nothing to be desired. All of the controls are within easy reach from the air-suspension seat which supports the driver's back. Maintenance and service support is also easy to reach: Thanks to the large and easily accessible service doors and clear layout of the most important components, this work is quick and easy to complete.

DIMENSIONS

Agile power – the SY215C works through its programme quickly and with great power. This excavator has great power reserves in its 23+ tonnes. The machine is mounted on a stable HD undercarriage so that it can be used to the full.



SAFETY

Safety as a production factor – it is only possible to work cost-effectively if you work safely. This is why the large safety package has everything included as standard, from a travel alarm to the rotating beacon, and from the boom safety valve to the overload warning for lifting and the camera.

COMPONENTS

High quality and tried-&-tested – the water-cooled Cummins diesel engine with common rail technology and AdBlue system guarantees reliable performance, even under tough working conditions. The complete package is rounded off by the finely tuned Kawasaki hydraulic system.

ECONOMY

Power and efficiency – the smart hydraulic control system adapts the pump power to the available engine power. This means greater efficiency and lower fuel consumption, thereby providing excellent cost-effectiveness.

ECONOMY

Cost-effectiveness thanks to maximum flexibility

Whether digging, loading, demolishing, transporting, hammering, or performing other tasks, the SANY SY215C tackles a wide range of tasks without compromise – and without long changeover or waiting times. The pre-installed quick-coupler line means that many attachment devices can be fitted.



QUALITY

EVERYTHING IN VIEW, EVERYTHING UNDER CONTROL

To enable efficient work at the construction site, you can, for example, save the required working pressures and oil flow for the two proportional auxiliary lines for up to five attachment devices in each category. Simply enter the name of the attachment in the large, high-resolution 10" touch display and assign the required value to the tool. This makes changing attachments on the job site quick and uncomplicated - time and costs can be significantly reduced as a result. In addition, the large touch display with its simple menu allows intuitive navigation and monitoring of all important parameters.



COMPONENTS

Improved performance thanks to optimised hydraulics

The position-controlled hydraulic system adjusts the required pressure- and oil quantity according to requirements. The powerful, variable piston-pumps reach a flow rate of 2 x 241 l/min and therefore achieve a very high level of efficiency at a low engine speed.



**Absolute reliability –
for peace of mind!**

SANY's five-year warranty* gives you the assurance that you can fully count on your equipment.

* With participating partners

EFFICIENCY, COST-EFFECTIVENESS AND USER EXPERIENCE



USER EXPERIENCE

THE NEW COMFORT ZONE

For drivers to fully concentrate on their work, they first need to be sitting comfortably. The individually adjustable, air-suspension seat offers a comfortable workstation from which all of the controls are within easy reach. At the forefront, alongside the ergonomic controls, is the 10" touch display. This displays razor-sharp images from both cameras, and has intuitive controls which allow all relevant machine parameters to be set with great ease, in all common European languages. Naturally, the consoles move up and down with the seat, thus providing the best possible protection for the operator even in the event of impacts. The flat design of the engine cover allows a view of the rear working area.

The automatic climate control system which provides pleasant temperatures even in the summer, the powerful heating, and the radio with an additional USB port for the driver's own audio devices all comes as standard, as do the large storage compartments for everything the driver needs close to hand.

COMPONENTS

Improved performance thanks to optimised hydraulics

The position-controlled hydraulic system adjusts the required pressure and oil flow according to requirements. The powerful, variable piston pumps reach a flow rate of 2 x 241 l/min and therefore achieve a very high level of efficiency at a low engine speed.

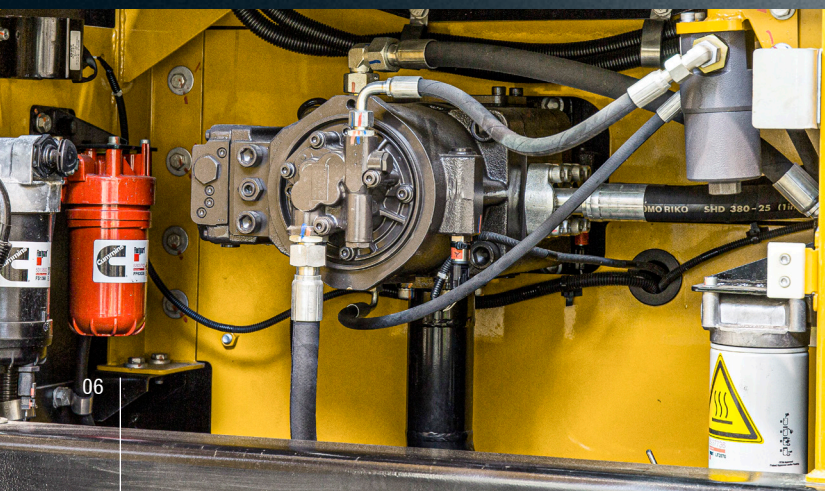

Our highlights – the added benefits SANY offers you:

- + Large, high-resolution 10" touch display
- + 2 cameras
- + Seat with adjustable consoles
- + 5 different attachments per category programmable (name, pressure, oil flow)
- + 2 proportional control circuits as standard
- + Comfortable switching of hammer/shear hydraulics

USER EXPERIENCE

Minimising maintenance times and maximising operating times

All serviceable components are easily accessible. This means that any maintenance and service support can be carried out efficiently and safely, reducing unproductive downtime and increasing machine availability.

Daily routine checks in particular can be carried out quickly, easily and safely by hand, because handrails, non-slip treads. A lot of maintenance tasks, such as cleaning the air filter, are already possible from the ground.

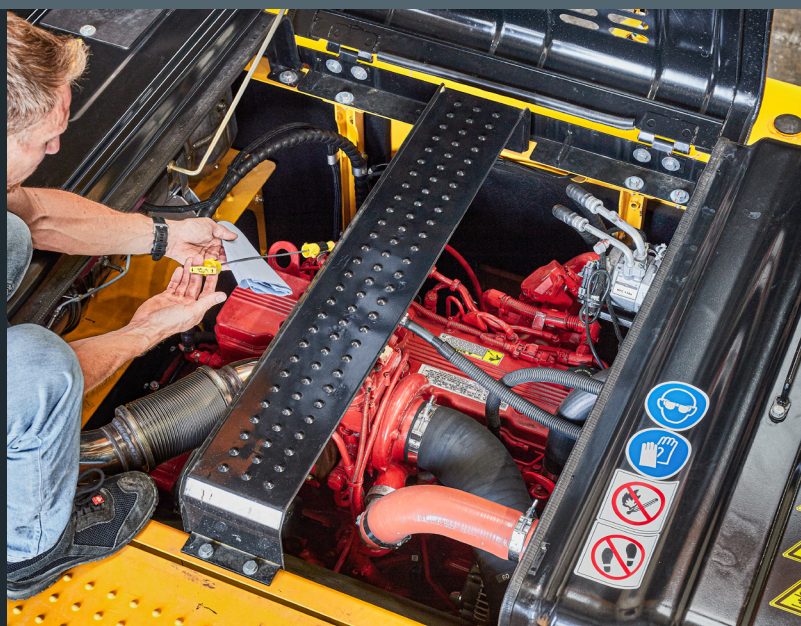

QUALITY

A very stable foundation

The machines have a great deal of work to do during their tough day-to-day work on construction sites. This is why – from the design stage, to selecting the materials used, quality and conducting the final checks – all excavators by SANY are designed to be robust. For instance, all welded seams are computer-controlled by robots – this maximum precision ensures stability and reliability.

SAFETY

Best visibility even in poor lighting conditions

Good visibility is required for precise, quick work. In the worst-case scenario, the SY215C itself will provide sufficient lighting. The operating area is illuminated by two LED roof working lights, two LED working lights on the boom, one in the upper structure and an LED working light facing backwards. The high-quality LED working lights not only stand out thanks to their particularly good illumination, but also due to their low power consumption and extreme durability, while also being virtually maintenance-free. For enhanced safety, two cameras are also provided to show all poorly visible areas of the machine. With a single tap, the images can be combined or shown individually on the high-resolution display.



TECHNICAL SPECIFICATIONS

MOTOR

Model	CUMMINS QSB6.7
Type	Water-cooled, 6 cylinder, with commonrail and Adblue
Exhaust emissions	Stage V
Rated power	129 kW / 2 200 rpm
Max. torque	1 472 Nm / 1400 rpm
Displacement	6 700 ccm
Batteries	24 V

HYDRAULIC SYSTEM

Mainpump	Variable-capacity piston pump
Max. oilflow	2 × 241 l/min
Travelmotor	2 x Axial piston motor with parking brake
Swingmotor	Axial piston motor with swing holding brake

RELIEF VALVE SETTINGS

Implement circuit	343 bar
Power boost	373 bar
Swing circuit	275 bar
Travel circuit	343 bar
Pilot pressure	39 bar

SERVICE REFILL CAPACITIES

Fuel tank	370 l
Engine coolant	27.6 l
Engine oil	27 l
Drive (per side)	5.5 l
Adblue	45 l
Hydraulic oil tank	200 l

PERFORMANCE

Swingspeed	11 rpm
Max. travel speed	High 5.4 km/h, slow 3.3 km/h
Max. travel force	191 kN
Gradeability	35°
Bucket capacity	1.2 m ³
Groundpressure	0.50 kg/cm ²
Bucket digging force ISO	143 kN
Arm digging force ISO	115 kN

UNDER AND UPPER STRUCTURE

Boom length	5 700 mm
Arm length	2 950 mm
Bottomrollers	9
Toprollers	2
Rotation device	Planetary gear reducer driven by an axial piston motor, automatic hydraulic released slewing brake

OPERATING Weight

SY215C 24 000 kg

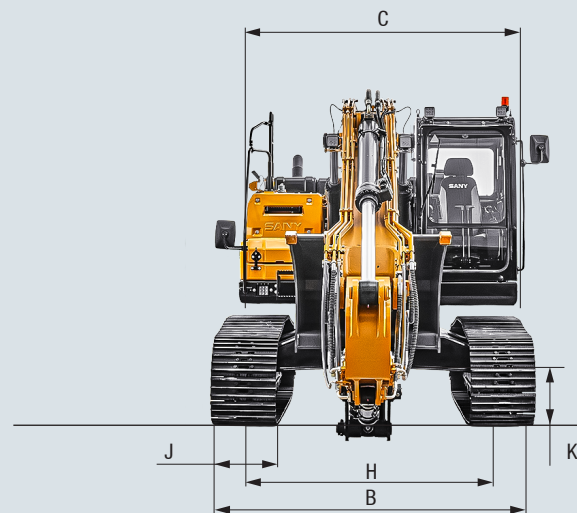

LIFTING CAPACITIES*

Load point height	Radius				Max. digging reach							
	3.0m/9.8ft	4.5m/14.8ft	6.0m/19.7ft	7.5m/24.6ft	Capacity							
								mm				
7.5 m kg			4232	4232	3449	3449	6275					
24.6 ft lb			9330	9330	7604	7604	13834					
6.0 m kg			5360	5150	5290	5130	7360					
19.7 ft lb			11817	11354	11662	11310	16226					
4.5 m kg			5900	5143	5380	5010	5290	4610	8025			
14.8 ft lb			13007	11338	11861	11045	11662	10163	17692			
3.0 m kg	7499	7499	6570	5890	5690	4830	5380	4180	8370			
9.8 ft lb	16532	16532	14484	12985	12544	10648	11861	9215	18452			
1.5 m kg	8954	8197	7360	6330	6170	4540	5630	3880	8435			
4.9 ft lb	19740	18071	16226	13955	13602	10009	12412	8554	18596			
Ground line	kg	7388	7389	9726	7832	7123	5265	5689	3890	3409	3409	8230
	lb	16287	16290	21442	1726	15703	11607	12542	8576	7515	7515	18144
-1.5 m kg		11636	11637	9745	7110	7721	5160	5589	3851	3967	3730	7730
-4.9 ft lb		25653	25655	21484	16997	17022	11376	12321	8490	8746	8223	17041
-3.5 m kg				12677	12677	9026	7778	6691	5199	5161	4407	6870
-9.8 ft lb				27948	27948	19899	17147	14751	11462	11378	9716	15146
-4.5 m kg				9843	9843	7102	7102			5483	5483	5485
-14.8 ft lb				21700	21700	15657	15657			12088	12088	12092

*at 600 mm track pads width

With the SANY SY215C, you do not need to worry about additional parts. Everything you need for easy, comfortable work is included as standard.



OPERATORS COMFORT / CAB

Heater	●
Automatic air conditioning C/H	●
Radio and speaker	●
Armrests (adjustable)	●
Airsuspension seat	●
Heated seat	●
Wiper	●
Sprayer f. wiper	●
AUX 1 on Joystick	●
AUX 2 on Joystick	●
Removable front-window	●
Sky light openable	●
Integrated cooling box	●
10" touch display	●

WORKING EQUIPMENT

Boom and arm load holding valves with overload indicator	●
Double acting circuit for hydraulic quick coupler with piping	●
Breaker&Shear line proportional on joystick with piping	●
Rotation line proportional on joystick with piping	●
Rotation line on Joystick with piping	●
Flow adjustment for attachments	●

UNDERCARRIAGE

Steel tracks 700	●
Steel tracks 600	●
Steel tracks 800	●
Holes/loops for fixing	●

WORKING LIGHTS

Lights – front (LED)	●
Lights – boom (LED)	●
Lights – platform (LED)	●
Lights – back (LED)	●

ENGINE

Auto idle	●
Diesel filter	●
DOC	●

HYDRAULIC SYSTEM

Swing brake	●
2 speed travel	●
Piping for additional hydraulic function AUX 1	●
Piping for additional hydraulic function AUX 2	●
Hydr. Pre-pressure operating joysticks	●
Mainfilter	●

SAFETY

Battery master switch	●
Travel Alarm	●
Warning beacon	●
Camera (Rear & Side)	●
Handrails	●
Lockable hoods	●
Lockable fuel cap	●
Standard equipment ● Special option ●	●

The standard and special options differ depending on the country in which the crawler excavator is delivered. If you have any questions, please contact your dealer directly.

Parts supply – quick and reliable

With the purchase of a SANY crawler excavator you have made an investment in the future. Fast availability of spare parts is your guarantee of minimal downtimes and failure times.



A SERVICE YOU CAN RELY ON

Just as we do with our excavators, we also demand high quality and reliability of our service products. This underlines our equipment's performance in terms of their durability and their excellent price-performance ratio. After all, maintenance is crucial

for efficiency, cost-effectiveness and safety. Your SANY dealer is happy to help you with a comprehensive range of services to ensure that your machine continues operating efficiently in the long term.

SANY – flexible, fast and always there for you

Rapid assistance, tailored advice and a reliable supply of original parts – that is what we mean by a premium service.



The added benefits SANY offers you:

- + Experienced dealer network throughout England, Wales, Northern Ireland and Ireland
- + Direct sales and support route in Scotland
- + Dedicated SANY team based in the UK to support you and your product
- + UK office and parts warehouse to ensure SANY excavators are fully supported

* To locate your nearest dealer, visit <https://www.sanyuk.com>.

Detailed information in black and white

Handbooks and documents are available for all SANY crawler excavators, and these can help you with operation, maintenance, servicing and repairs. These include operating and maintenance instructions and technical specifications.



THE ALLROUNDER THAT PICKS UP EVERYTHING

The SANY SY215C is a powerful all-rounder which combines flexibility and power. It can therefore perform various tasks in a wide range of applications and its robust design means that it is comfortable even with difficult tasks and tough environments.



DURABLE AND ROBUST

The SY215C can be used whenever the going really gets tough. This means that it must be able to withstand a great deal. No problem, as with its reinforced, extremely robust undercarriage and particularly clean, robot-welded seams, the SY215C is exactly the right excavator for hard day-to-day work on construction sites.

COMFORTABLE WORKSTATION

You know there are good ergonomics when you can still concentrate on your work after several hours. No problem in the cockpit of the SY215C because the seat and controls have been designed for practical requirements. For example, the additional hydraulic circuits can be operated using the joysticks.

AGILE POWER

The stable heavy-duty undercarriage and its sheer mass provide the SY215C with the stability required to make quick and powerful operational movements. The excavator can therefore even tackle large tasks in a short time.

SAFETY AS A PRODUCTION FACTOR

The clever cab structure provides a clear view of the working area and the camera supplied as standard provides a good overview, including of the area behind the excavator. The overload warning and the safety valve are absolutely essential when the boom is used for lifting. Moreover, when performing maintenance and servicing tasks, handrails and anti-slip tread surfaces provide you with the required stability.

HIGH QUALITY AND TRIED-AND-TESTED

With its maximum torque of 1472 Nm at 1400 rpm, the very strong six-cylinder Cummins engine brings an incredible amount of power.

EFFICIENCY AND POWER

In conjunction with the electronic fuel injection, the autothrottle function adjusts the engine speed to the power required. This means that the smart hydraulic system reduces the fuel consumption, engine wear and exhaust emissions. In addition, the excavator's low maintenance requirements and long intervals between maintenance save operating costs and increase the cost-effectiveness.

Engine	CUMMINS QSB 6.7
Rated power	129 KW / 2 200 rpm
Max. torque	1472Nm / 1 4 00 rpm
Max. travel speed	5.4 km/h
Swingspeed	11 rpm
Mainpump	Variable-capacity piston pump
Max. oilflow	2 × 241 l/min

Not all products are available in all markets. As part of our continuous improvement process, we reserve the right to modify specifications and designs without giving prior notice. The figures may contain additional options.

SANY

Quality Changes the World

SANY HEAVY MACHINERY (UK) LTD
info@sanyuk.com
www.sanyuk.com